

WBS/FBS
MAINTENANCE BYPASSES
AUTOMATIC VERSION

- 1. GENERAL DESCRIPTION. 3
- 2. INSTALLATION. 3
- 3. OPERATION 4
- 4. Diagram WBS2kVA11A (FBS 007 /02 /03) 5

1. GENERAL DESCRIPTION.

This manual covers the WBS2kVA11A (formerly FBS 007) maintenance bypass. It is an automatic/manual bypass recommended for all UPS installations where the load cannot be interrupted during normal operation. A typical extended runtime UPS installation is shown below in *figure 1*.

The WBS2kVA11A bypass has a manual, two-pole switch. The switch is of the 'make-before-break' type and guarantees a 'break-free' transfer between its two positions NORMAL and BYPASS.

In the NORMAL position the load is supplied from the UPS. In the BYPASS position, the load is supplied directly by the mains supply. When the switch in the BYPASS position, the UPS may be switched off for maintenance or removal.

The WBS2kVA11A has the added safety feature of automatic bypass. Should the UPS be unable to supply power to the load, a switch, internal to the bypass, will automatically transfer the load to the mains supply. In this condition the FAULT neon will glow red.

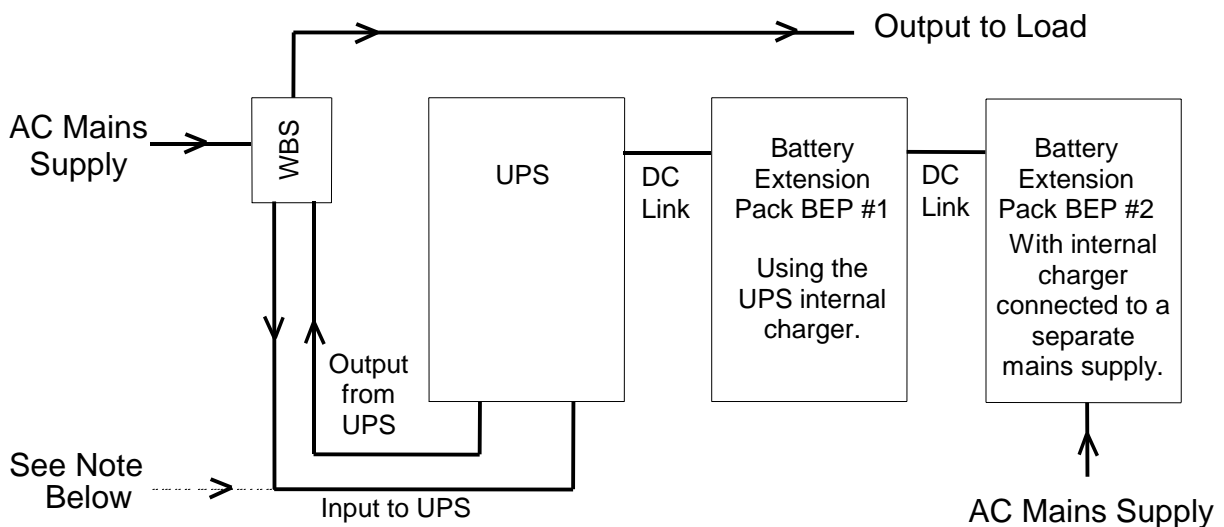

Figure 1. Typical UPS, 7 hour extended runtime

NOTE 1:

To reduce the possibility of a single point failure causing disruption to the critical load the UPS input can be connected to a separate supply. To achieve this do not fit the IEC-IEC lead from the UPS input to the WBS bypass, but replace with an IEC - UK Plug lead. Use this lead to connect the UPS input to the separate supply.

The WBSs and UPS supplies must be on the same phase.

Ensure that there is discrimination between the fuse/mcb feeding the UPS, and that feeding the bypass. This will ensure that in the event of a UPS failure that also trips the UPS supply protection, the bypass supply will remain. Fuse rating for the UPS supply can be found in the UPS operation manual.

2. INSTALLATION.

WARNING: - The following procedure must be followed exactly. Failure to do so, could lead to exposure to hazardous voltages, and disruption of the supply to the protected equipment. It is recommended that the following procedure is carried out by a qualified electrician.

Before commencing the installation ensure that the WBS is suitable for the UPS system for which it

is to be used.

THIS EQUIPMENT MUST BE EARTHED.

Mount the WBS securely to an even surface (*e.g. wall*). This can be achieved using the mounting holes located in the rear of the enclosure (see section 4). Once the WBS is securely mounted the connections can be made as described in the next section.

2.1. Load sizing.

The WBS2kVA11A bypass has a maximum total load rating of 10A. This allows the bypass to supply 220/230/240V 50Hz loads up to 2kVA. For loads exceeding 2kVA there are a range of bypasses to suit most applications. For 110Vac versions the rating is still 10Amps but only 1kVA.

2.2. Packing list.

- 1 x Bypass Switch
- 1 x IEC to IEC lead.
- 1 x 13Amp BS plug.
- 1 x Right angled IEC socket
- 4 x Rubber feet
- 1 x Operation manual (Man488)

2.3. Connecting the WBS bypass switch.

*****NOTE: Ensure that the UPS is completely switched off and cannot activate itself. All front panel and rear panel ac and dc switches must be in the "OFF" position.**

Connect the UPS output to the WBS plug marked INPUT FROM UPS using an IEC to IEC lead. Connect the UPS input to the WBS socket marked OUTPUT TO UPS using an IEC to IEC lead (*see note 1*).

Connect the load(s) to the WBS output cable marked LOAD (an IEC socket is supplied for non hard-wired applications). Ensure the wiring is correct (see below).

Connect the mains supply to the WBS input cable marked MAINS INPUT (a 13Amp plug is supplied for non hard-wired applications). Ensure the wiring is correct (see below).

BROWN = LIVE

BLUE = NEUTRAL

GREEN/YELLOW = EARTH

2.4. Powering up the WBS and UPS.

With the WBS switch in the BYPASS position, switch on the mains power source to the WBS. The UPS MAINS IN indicator should light (depending on UPS type).

Start the UPS as described in the UPS operation manual, and confirm normal operation.

Rotate the WBS switch to the NORMAL position.

Switch on the load. The load is now protected by the UPS.

3. OPERATION

3.1. Manual switching to BYPASS.

Check that the UPS is not operating on batteries.

Turn the switch to the BYPASS position. The load is now unprotected, being fed directly from the incoming mains supply. The UPS is still connected to the mains supply and tests may be performed on it without disruption to the load.

3.2. Automatic switching to BYPASS.

If the UPS output fails the WBS will automatically transfer the load to the mains supply, and the FAULT neon will glow red.

Turn the manual switch to BYPASS (see section 3.1).

Refer to the UPS operation manual.

[MAN488 Issue 3](#)

3.3. Disconnecting The UPS.

Confirm that the UPS is not operating on batteries.

Rotate the WBS switch to the BYPASS position.

Switch off the UPS.

Remove the INPUT FROM UPS and OUTPUT TO UPS leads from the WBS bypass box (See Note 1).

The UPS can now be removed for maintenance. The load will continue to be fed from the mains supply through the WBS. The WBS switch must be left in the BYPASS position in order to continue supplying the load, and to avoid hazardous voltages from appearing on the UPS output cable.

Reconnecting the UPS.

Re-connect the INPUT FROM UPS and OUTPUT TO UPS leads to the WBS bypass box (See Note 1).

Switching back to Normal operation.

Ensure that the UPS is connected to the mains.

Re-start the UPS, as described in the UPS operating manual.

Rotate the WBS switch to the NORMAL position the UPS is now supplying the load.

4. Diagram WBS2kVA11A (FBS 007 /02 /03)

