

**BEP/REP 60V, 72 & 120 VOLT
/01, /02 SERIES
BATTERY EXTENSION PACKS
FOR ELITE ETD/RTD SERIES UNINTERRUPTIBLE
POWER SYSTEMS (UPS)**

1. INTRODUCTION.....	3
1.1. Precautions and Safety Warnings	3
1.2. Battery/Rack Extension Packs (BEP/REPs)	3
1.3. Model Number Explanation (BEP)	3
1.4. Model Number Explanation (REP)	3
2. INSTALLATION	4
2.1. BEP/REP Connections	4
2.2. Positioning	4
2.3 Connection Scenarios With A Maintenance Bypass	4
2.3.1 Single Mains Supply For the Entire System	5
2.3.2 Separate Mains Supply For The BEP/REPs With Chargers	5
2.3.3 Connections REP	6
2.3.4 Connections BEP	7
2.4. Rear Panel Connectors (BEP/REP)	8
2.5. Rear Panel locking plates.....	9
2.6. Front Panels (BEP/REP)	9
3. OPERATION.....	10
3.1. Start up of the System (60V)	10
3.2 Start up of the System (120V)	10
3.3. Battery Test - Software Configuration	10

1. INTRODUCTION

1.1. Precautions and Safety Warnings

- ◆ Hazardous voltages exist within the Battery Extension pack (BEP). The cover must be removed by authorised and trained service personnel only.
- ◆ The total or partial current in the battery can cause electric shocks. Make sure that the battery terminals are not touched once the cover is removed.
- ◆ If the batteries are to be replaced, the 'old' batteries must be disposed of in accordance with local environmental and safety standards. They are toxic waste!
- ◆ Do not throw the batteries on to a fire: they may explode.
- ◆ Do not attempt to open the batteries: they do not require maintenance and the acid electrolyte is harmful to skin and eyes, and is toxic if inhaled or swallowed.
- ◆ If the BEP/REP is connected to the UPS and the safety fuses are inserted, the external sockets of the UPS may be live.
- ◆ Do not start or install the BEP/REP if there is any visible damage, leaks or white powdery residue on the exterior of the unit.
- ◆ The removable mains cable is intended to be used as a safety cut-out. Take care to leave a suitable amount of free space at the rear of the BEP/REP to enable easy access to the connection points.
- ◆ Do not site the BEP/REP in any location where water or any other liquid or foreign objects could enter the unit.
- ◆ If an emergency arises, remove the mains cable (*safety cut-out*) from the BEP/REP or wall socket before attempting to handle the BEP/REP.

1.2. Battery/Rack Extension Packs (BEP/REPs)

A BEP/REP will increase the amount of battery runtime the UPS can supply when the mains fails or fluctuates.

There are several sizes of BEP/REP cabinets. Each cabinet can hold a different quantity and type of battery, and where necessary an additional battery charger. BEP type 'X' is designed to sit alongside the UPS. **See 2.3.3**

1.3. Model Number Explanation (BEP)

A BEP contains a set of sealed lead acid maintenance-free batteries and provides a 60, 72 or 120Vdc supply suitable for use with an Elite UPS. It extends the standard runtime of a UPS by up to eight hours. The /02 series also contains a battery charger and provides a visual indication of mains and charger status.

Model Number	Battery Configuration			Base Models	
	Total Ah	Strings	Qty x Ah	No Charger	With Charger
BEP060024X/zz	24	1	5x24	/01	/02
BEP060038X/zz	38	1	5x38	/01	/02
BEP072024X/zz	24	1	6x24	/01	/02
BEP072038X/zz	38	1	6x38	/01	/02
BEP120024X/zz	24	1	5x24+5x24	/01 + /02 Installed as a pair.	
BEP120038X/zz	38	1	5x38+5x38	/01 + /02 Installed as a pair.	

1.4. Model Number Explanation (REP)

A REP contains a set of sealed lead acid maintenance-free batteries and provides a 60, 72 or 120Vdc supply suitable for use with an Elite UPS. It extends the standard runtime of a UPS by up to eight hours. The /02 series also contains a battery charger and provides a visual indication of mains and charger status.

Model Number	Battery Configuration			Base Models	
	Total Ah	Strings	Qty x Ah	No Charger	With Charger
REP060024D/zz	24	1	5x24	/01	/02
REP060038D/zz	38	1	5x38	/01	/02
REP120024D/zz	24	1	5x24+5x24	/01 + /02 Installed as a pair.	
REP120038D/zz	38	1	3x24	/01 + /02 Installed as a pair.	

2. INSTALLATION

WARNING: ALL THE OPERATIONS IN THIS SECTION MUST BE PERFORMED BY AUTHORISED AND QUALIFIED PERSONNEL.

2.1. BEP/REP Connections

Diagram 1 shows the layout for the BEP/REP and charger connections.

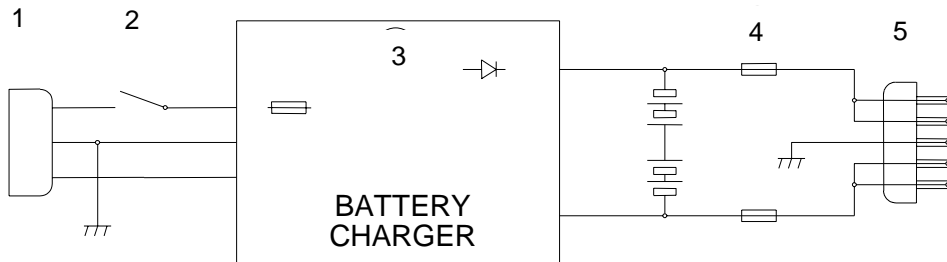
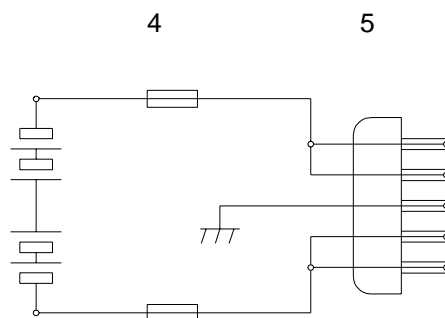

Diagram 1: BEP/REP with built-in batteries and charger

1. AC mains connector cable.
2. Safety switch
3. Battery charger
4. Battery fuses
5. DC connector cable

Diagram 2 shows the layout for the BEP/REP connections.



1. AC mains connector cable
2. Safety switch
3. Battery charger
4. Battery fuses
5. DC connector cable

Diagram 2: BEP with built-in batteries only.

2.2. Positioning

Please observe the following when choosing where to position the BEP/REP and UPS:

- ◆ The surface must be stable and even.
- ◆ The location must not be exposed to direct sunlight or hot air.
- ◆ The ambient temperature of the room should be between 20°C and 25°C.
- ◆ The relative humidity of the room must not be allowed to exceed 90% at worst case.
- ◆ The location should allow at least 50mm of clear air flow around the UPS and BEP and none of the ventilation slots must be covered.
- ◆ The location should ensure that the interconnecting cables cannot be pulled accidentally or exposed to damage from falling objects or liquids.

2.3 Connection Scenarios With A Maintenance Bypass

There are two basic scenarios.

2.3.1 Single Mains Supply For the Entire System

This is the general layout adopted for most applications. A single mains supply is used to power both the bypass (which then supplies the UPS) and any BEP/REPs with chargers.

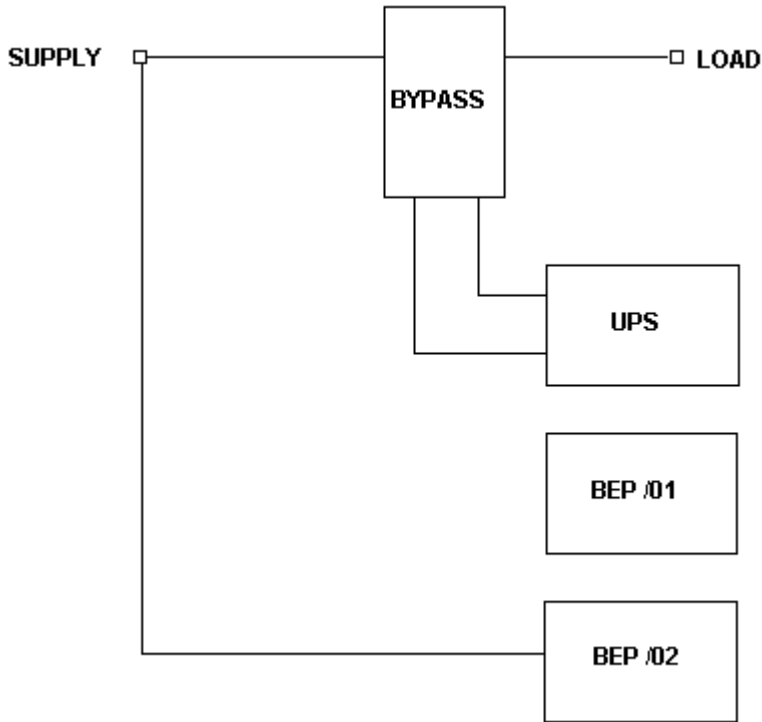

2.3.2 Separate Mains Supply For The BEP/REPs With Chargers

This is the preferred option because should the supply to the bypass be accidentally removed the battery charges continue to charge the batteries.

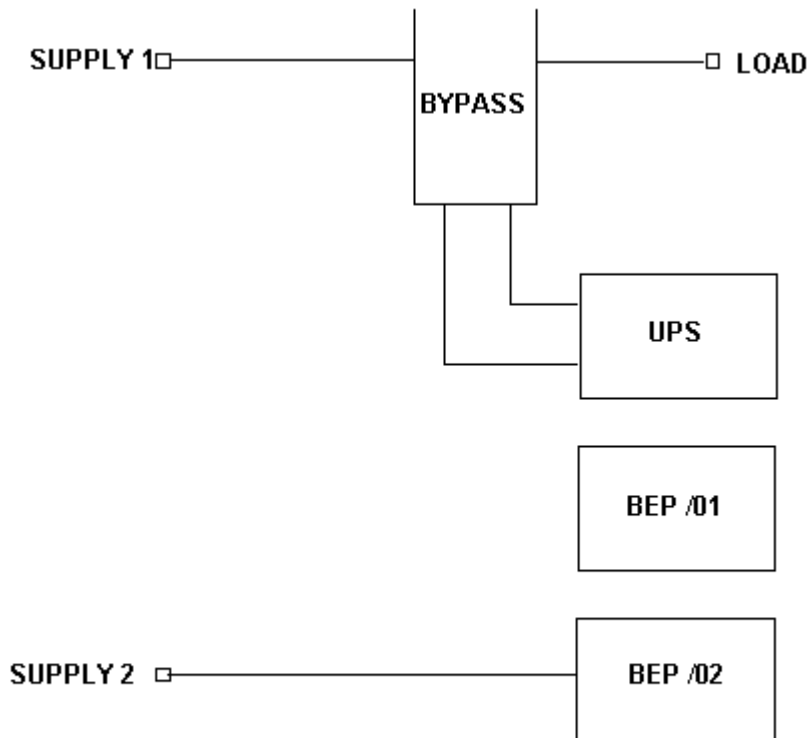

NOTE: Supply 1 & 2 must be on the same phase.

2.3.3 Connections REP

(a) Multiple units in parallel for extended 60V runtime.

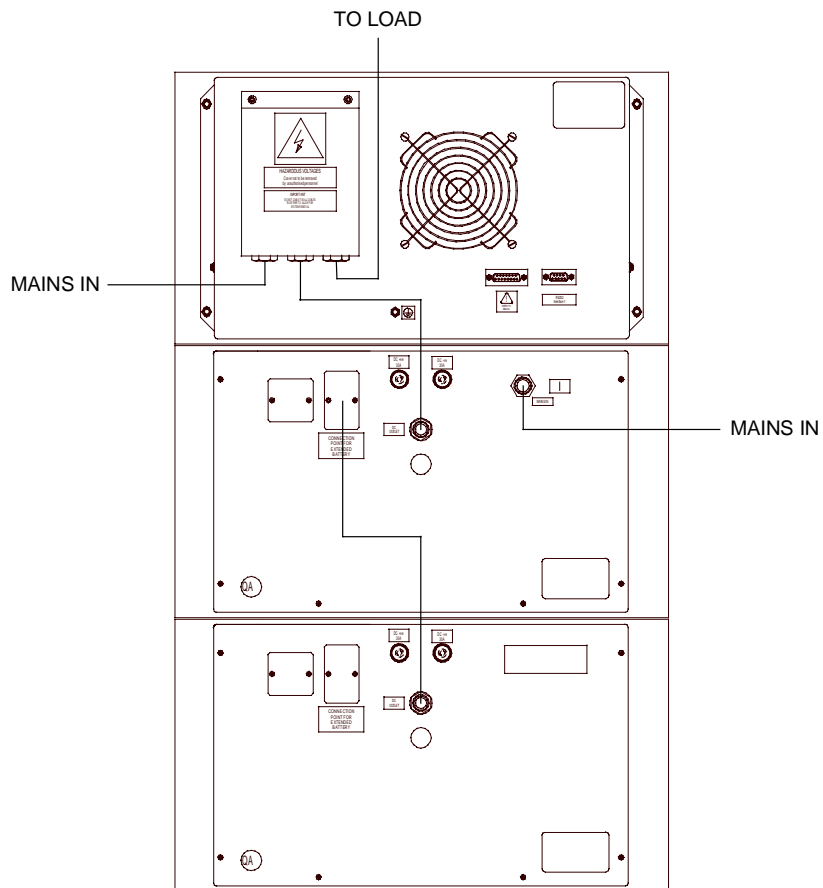

(b) Multiple units in series for 120V system.

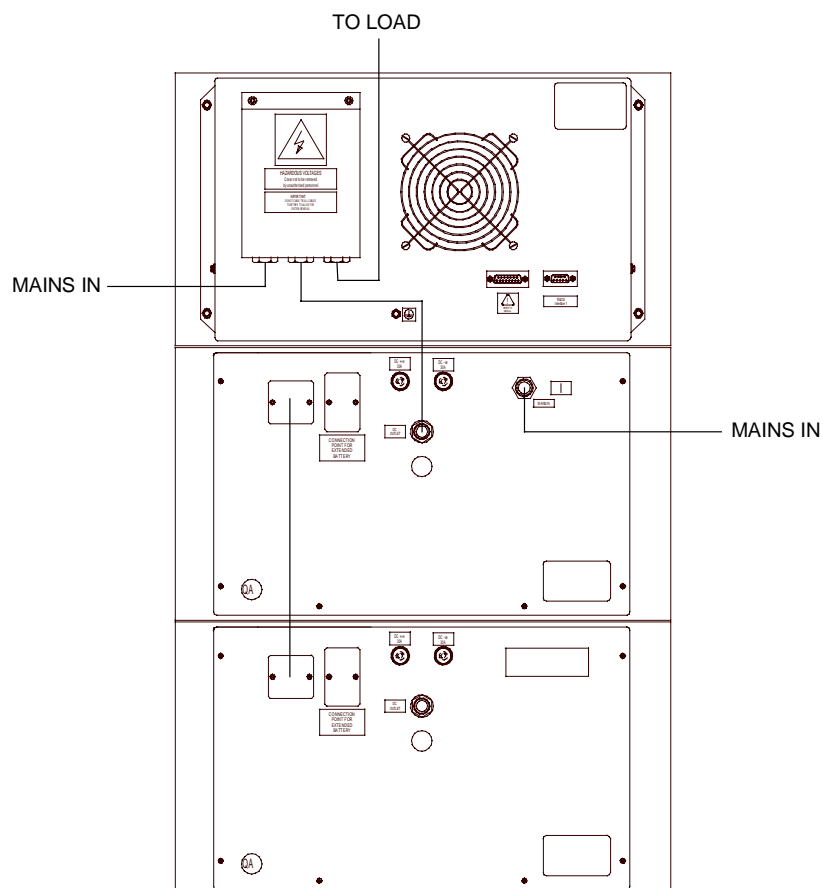

2.3.4 Connections BEP

(a) Multiple units in parallel for extended 60V runtime.

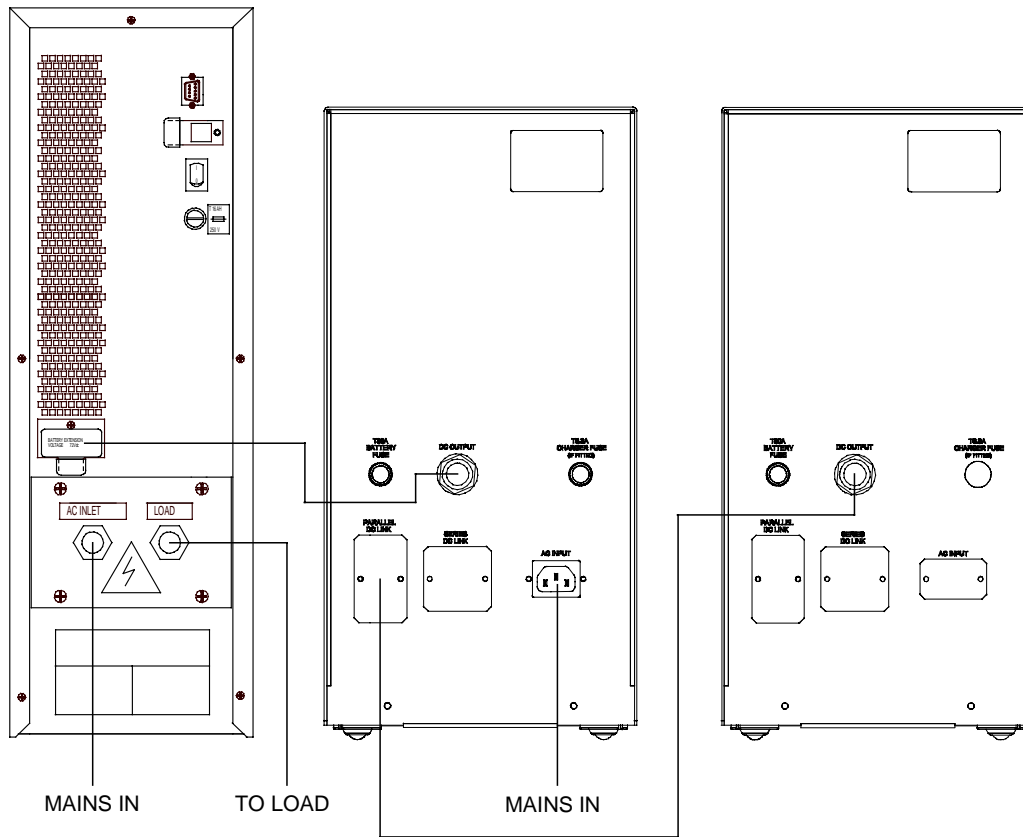

(b) Multiple units in series for 120V system.

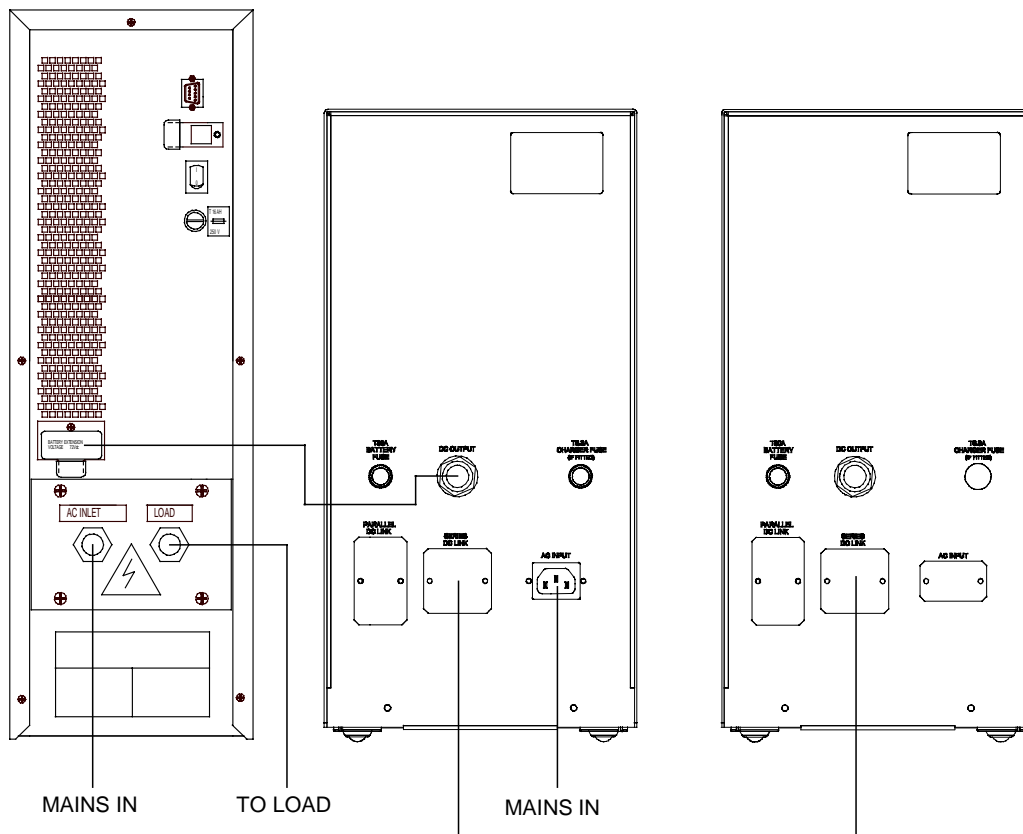

2.4. Rear Panel Connectors (BEP/REP)

There are two basic layouts to the rear of a BEP/REP: with and without charger.

(a) BEP X case rear panel connections.

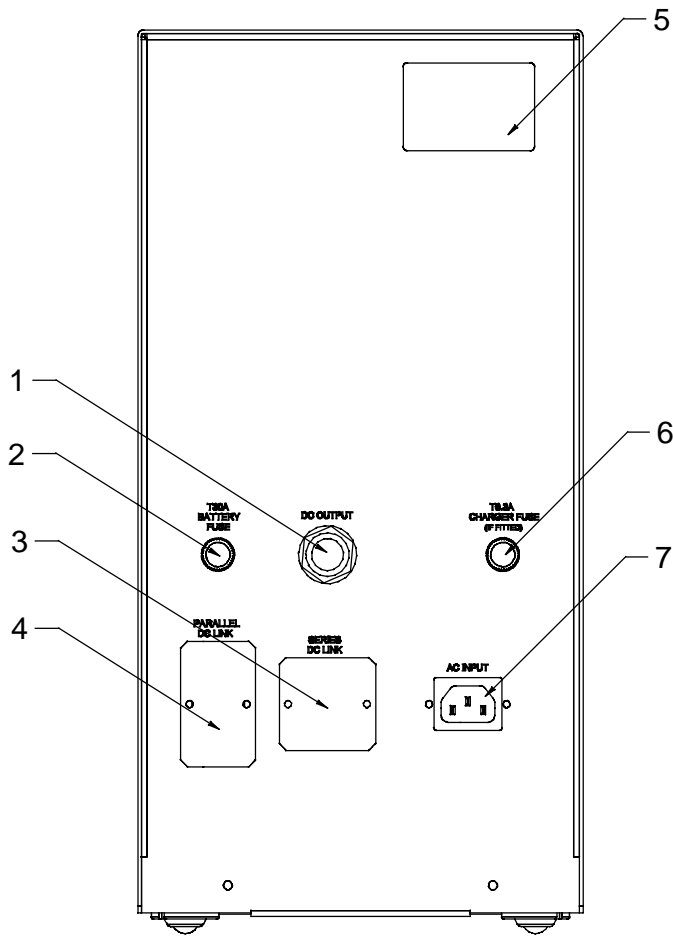

1. DC Output cable.
2. 30A Output fuse.
3. Series link/Blanking plate.
4. Parallel link/Blanking plate.
5. Specification/rating plate.
6. Charger fuse (36V only).
7. AC input (Hardwired or IEC).
8. Mains switch (where fitted).

(b) REP D tray rear panel connections.

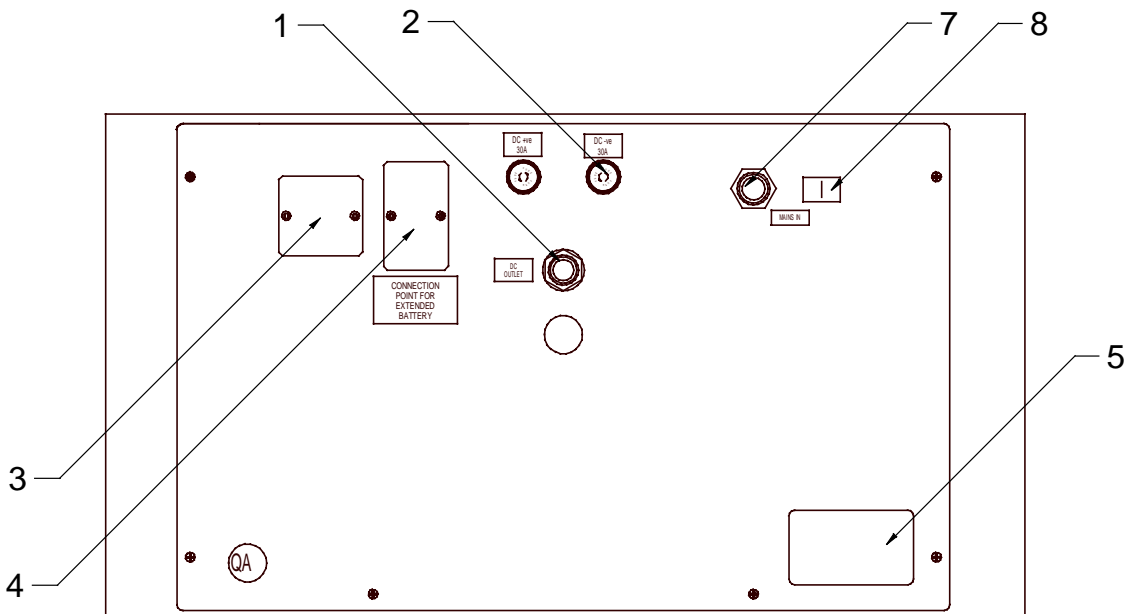

2.5. Rear Panel locking plates.

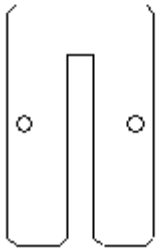

Locking plate for rear of UPS

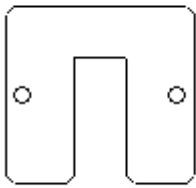

Series Link Locking plate

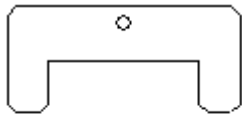

UPS locking plate

2.6. Front Panels (BEP/REP)

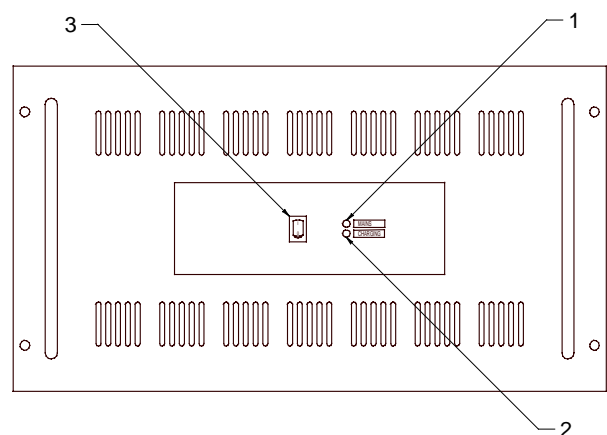
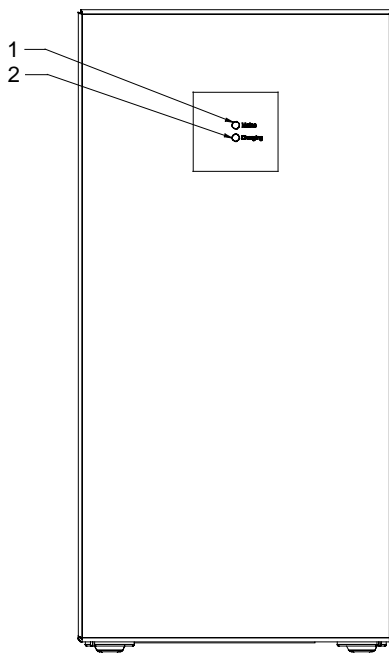

1. LED "MAINS" (yellow) – Lit when mains voltage present.
2. LED "CHARGER" (green) – Lit when charger OK.
3. Mains switch (where fitted).

3. OPERATION.

3.1. Start up of the System (60V)

- ◆ Install the BEP/REP with the UPS switched off.
- ◆ Check that the battery current of the BEP/REP is suitable for the UPS (check the data label on the back of the BEP/REP and the UPS manual).
- ◆ Connect the battery exit cable to the expansion socket on the back of the UPS. Ensure that the screws of the protective cover are tight.
- ◆ Insert the two DC fuses used in the appropriate fuse carriers at the back of the BEP/REP.
- ◆ Connect the supply cable of the BEP to the supply. In the X & D version switch the mains switch to the ON position.
- ◆ Switch on the UPS.
- ◆ After about 30 seconds, check that the UPS is functioning correctly: simulate a black-out by disconnecting the supply cables of the UPS and the BEP from the plug. The load should continue to be supplied, and the “battery working” LED should light up on the front panel of the UPS. A bleep should be heard about every 7 seconds. The UPS should return to normal function after the supply cables are reconnected.

3.2 Start up of the System (120V)

- ◆ Place the BEP close enough to the UPS to allow easy connection, ensuring that both the UPS and Master unit are switched off before making any connections.
- ◆ Check that the BEP is suitable for the UPS, i.e. ensure the total battery voltage 120Vdc matches the voltage stated on the rear of the UPS. If you are unsure if the BEP is compatible with the UPS do not connect them.
- ◆ Remove the DC series link blanking plate on the rear of both battery boxes and connect the series link cable (*supplied*) between to the two connections. Fit the Series locking plates to both boxes by sliding it over the wires and securing in place using the existing screws.
- ◆ Remove the single screw securing the expansion socket protection plate from the rear of the UPS.
- ◆ Connect the DC supply cable on the rear panel of the Master BEP to the expansion socket on the rear of the UPS.
- ◆ Fit the UPS locking plate to the UPS using the existing screw.
- ◆ Insert the two fuses into the appropriate fuse carriers at the rear of the BEP (*if not already fitted*).
- ◆ Connect the supply cable to the Master unit and to the mains supply.
- ◆ Switch the On/Off switch on the rear of the Master unit to ON. The LED (*Mains*) on the front of the Master unit that signals the presence of power will immediately light up. After a few seconds' delay the LED that signals the battery charging function will light up.
- ◆ Switch on the UPS. After about 30 seconds, check that the UPS is functioning correctly: simulate a mains failure by disconnecting the mains supply cables to the UPS and the Master unit. The load on the UPS should continue to be supplied, and the “battery working” LED should light up on the front panel of the UPS. A bleep should be heard about every 7 seconds. The UPS should return to normal function after the supply cables are reconnected.

3.3. Battery Test - Software Configuration

The UPS should have been configured for the BEP/REPs supplied. If a BEP/REP has been added subsequently, to an existing installation, the UPS battery testing parameters will need to be updated. This is a software function that should be performed by the installer.

NOTE: If the battery box was supplied with the UPS, the battery Ah should already be factory set. If not follow the simple procedure below.

- ◆ Once the correct battery sizes have been established, connect the UPS (*via the comms lead*) to a computer through the 9 way connector on the rear panel. (*The software and communication lead are supplied with the UPS*).
- ◆ With the software application open and the UPS switched on, using a mouse click on the shaded box marked PASSWORD once the next screen appears enter the password ' pigreco ' then click on OK. This will then return to the original screen.
- ◆ Once you are back to the original screen, click on the shaded area marked CONFIGURATION. At the bottom of the next screen you will see a box marked BATTERY NOM . CAPACITY. Click on this box and enter the new total battery Ah.
- ◆ Check that the total battery Ah is correct before clicking on the OK box. The new battery Ah has now been stored in the UPS. Exit the software.
- ◆ If the test shows that the batteries are below 60% efficiency, the UPS will alarm. The battery set(s) should be replaced immediately.