

Installation Instructions for Advance Electronics CVTs

1. Introduction

These instructions are supplied as guidance for the installation of an Advance Electronics Constant Voltage Transformer (CVT). For more detailed information regarding these special power conditioning transformers please view the CVT Handbook, which is located on the Internet at the following address; www.aelgroup.co.uk/shared/pdf/hb.pdf, or contact a member of our technical sales team on (01978) 821000.

2. Specification

The full technical description for these products is described in our catalogue data sheet. Minor variations to the specification are described by the use of suffix numbers in the part number and specific drawings for these items are available on demand.

3. Unpacking & Siting

Remove the unit from its packaging and examine for external damage. Please advise your supplier and/or carrier if the unit is damaged in any way.

Before installation, check the specification/rating label on the rear of the unit and verify that the following four parameters are appropriate for your application:

Nominal input voltage / Nominal output voltage / Input frequency / Power rating

The unit should be installed in a well-ventilated location to allow natural air-cooling, and should be positioned as close as possible to the load it is protecting. If the unit is being wall mounted in a vertical position, please ensure that the end containing the capacitors is lower.

4. Wiring

4.1. Units supplied with socket(s) and plug or cable:

Plug the critical load into the output socket on the unit, and plug the input lead of the unit into a convenient mains socket.

In cases where the input cable is supplied without a plug, the unit must be hard wired to a suitable supply. This supply must have adequate fusing or magnetic circuit breaker protection as described in Section 6.

4.2. Units supplied with screw-in terminal block connections:

The cover or cover plate (if present) must be removed to gain access to the terminals.

On small units this is usually a rectangular plate fitted with 4 screws. On large units it is the cover nearest the inlet/outlet holes/grommets.

Suitably glanded cables/wires should be fed through the appropriate holes, and connected as indicated by the internal connection label.

Units with a "stroke" number suffix in the model number (e.g. AGT 1000/20) are bespoke models, and a factory drawing is sometimes required for connection details.

4.3. Units supplied with solder/screw tags:

Small ECVN type transformers (up to 100VA), are supplied with solder / screw tags labelled either 1 - 8 or 1 - 10. The input connection is made using tags 1 & 2, and the output connections are made using tags 5 & 6.

5. Earthing

All earthing connections are very important. All units MUST be safety earthed, although it is permissible to leave the output winding 'floating'.

The CVT is designed to isolate the protected load from noise on the incoming earth, as well as providing voltage regulation and noise attenuation. The output earth to the protected load may be connected to the incoming safety earth, but it must be realised that noise spikes on the earth may cause problems.

Ideal installations have the input of the CVT protected by the incoming safety earth, and a separate 'dedicated' earth provided for the critical load. This can be achieved using a ground rod, water pipe, or the metal structure of a tall building.

In cases where the load is partially protected (some peripherals unprotected by the CVT) we recommend that the low or 'neutral' side of the CVT is connected to a clean earth. This avoids a potential difference appearing between the floating output of the CVT and the unprotected peripheral.

When the neutral is connected to earth, current IEE regulations require a RCCD to be fitted if the CVT provides power to domestic outlet sockets.

Further attention should be given to ensure that the clean earth connections are wired in a 'star' configuration.

6. Fusing

The switch on current surge for a CVT power conditioner consists of two components. One of these is fixed at less than 8 times the running current for approximately 5 - 10 milliseconds (ms).

Superimposed on this will be a 'spike'. This is dependent on where in the supply cycle the CVT was turned off and where in the cycle it is turned back on. The spike will be less than 1 ms in duration and may vary from zero up to 25 times the normal running current if the supply is low impedance.

The input surge current at switch-on is not significantly affected by the output load condition. The surge current will be proportional to the applied line voltage.

CVTs draw large input currents at switch-on. In general this current will be twice that of a conventional transformer. The protective fuse must be rated accordingly.

For large units the best protection is a magnetic breaker suitable for inductive loads with a slow trip characteristic. These are known as type "D" or type "4" breakers. USA types have a dropout curve known as "66". (We can supply motor rated fuses for some applications).

Please refer to the following tables for fuse types and ratings.

6.1. 110Vac systems

VA rating	Amps @ 88Vac	BS88 Fuse	IEC269 Fuse	UK Holder	Cable sq mm	Earth loop Ohms
100	1.5	5A	5aM		1	13
200	2.7	10A	10aM		1	7.7
300	3.9	13A	13aM		1	4.4
400	5	13A	13aM		1	4.4
450	5.7	13A	13aM		1	4.4
650	8.7	13A	13aM		1	4.4
1000	13	20M25	20aM	A1	1.5	3
1500	19	32M50	32aM	A2	4	1.8
2100	27	32M63	32aM	A2	6	1.8
3000	39	63M80	63aM	A3	6	0.86
4000	52	63M100	63aM	A3	10	0.86
5000	65	100M125	100aM	A4	16	0.45
6000	78	100M160	100aM	A4	16	0.45
7000	88	100M200	100aM	A4	25	0.45
8000	107	200M250	200aM	B2	35	0.19
10000	134	200M250	200aM	B2	35	0.19
12500	158	315M355		B3	50	0.11
15000	189	315M355		B3	50	0.11
20000	267	315M355		B3	50	0.11
25000	334	400M450		B4	70	0.096
33000	441	400M450		B4	70	0.096
50000	693	630M670		C2	95	0.054

6.2. 230Vac systems

VA rating	Amps @ 192Vac	BS88 Fuse	IEC269 Fuse	UK Holder	Cable sq mm	Earth loop Ohms
100	0.7	3	3aM		1	13
200	1.3	5	5aM		1	13
300	1.8	5	5aM		1	13
400	2.3	10	10aM		1	7.7
450	2.6	10	10aM		1	7.7
650	4	10	10aM		1	7.7
1000	6	13	13aM		1	4.4
1500	9	13	13aM		1	4.4
2100	12	20M25	20aM	A1	1.5	3
3000	18	20M32	20aM	A1	2.5	3
4000	24	32M50	32aM	A2	4	1.8
5000	30	32M63	32aM	A2	6	1.8
6000	36	63M80	63aM	A3	6	0.86
7000	41	63M80	63aM	A3	6	0.86
8000	49	63M100	63aM	A3	10	0.86
10000	61	100M125	100aM	A4	16	0.45
12500	72	100M160	100aM	A4	16	0.45
15000	87	100M200	100aM	A4	25	0.45
20000	123	200M250	200aM	B2	35	0.19
25000	153	200M250	200aM	B2	35	0.19
33000	202	200M315	200aM	B2	35	0.19
50000	318	315M355		B3	50	0.11

6.3. 400Vac systems

VA rating	Amps @ 332Vac	BS88 Fuse	IEC269 Fuse	UK Holder	Cable sq mm	Earth loop Ohms
100	0.4	3A	3aM		1	13
200	0.7	3A	3aM		1	13
300	1	3A	3aM		1	13
400	1.3	5A	5aM		1	13
450	1.5	5A	5aM		1	13
650	2.3	10A	10aM		1	7.7
1000	3.4	10A	10aM		1	7.8
1500	6.4	13A	13aM		1	4.4
2100	6.8	13A	13aM		1	4.4
3000	10	20M25	20aM	A1	1.5	3
4000	14	20M25	20aM	A1	1.5	3
5000	17	20M32	20aM	A1	2.5	3
6000	21	32M50	32aM	A2	4	1.8
7000	23	32M50	32aM	A2	4	1.8
8000	28	32M63	32aM	A2	6	1.8
10000	35	63M80	63aM	A3	6	0.86
12500	42	63M100	63aM	A3	10	0.86
15000	50	63M100	63aM	A3	10	0.86
20000	71	100M125	100aM	A4	16	0.45
25000	89	100M160	100aM	A4	25	0.45
33000	117	200M250	200aM	B2	35	0.19
50000	187	200M315		B2	35	0.19

7. Installation

When large CVTs are installed, it is common practice to test that the unit is supplying an appropriate voltage prior to connecting up the critical load.

It is not recommended to leave a CVT running for long periods without a connected load. This is because it will consume electricity, and can reduce the life expectancy of the capacitors.

Depending on the measurements taken, some misleading results can be observed:

7.1. Input current seems high

The primary or input current at zero output load is significantly out of phase with the input voltage, therefore a wattmeter must be used to measure the input power. Input power at zero load is about 10% of unit rating VA.

7.2. Output voltage seems high

With no load the output voltage should be a maximum of nominal +8% (at nominal input volts). As a load is applied the output voltage will reduce.

If an unusual 'motor boating', 'humping' or 'rattling' noise occurs, this is due to marginal instability. Just switch off and on again. If it still persists contact our Sales Office for advice.

8. Health & Safety Data

8.1. Construction

The transformer consists of insulated copper wires, which have been wound onto an insulated former. These windings are then assembled onto steel laminations, and high voltage capacitors are added into a resonant circuit configuration.

8.2. Hazards

WARNING – HIGH VOLTAGE

The transformer must be correctly installed according to the requirements both of the current edition of the IEE Wiring Regulations and the manufacturers recommendations. Specifically, proper in-line fusing or other suitable protection must be supplied.

Output voltages can be very high and therefore suitable RCCD protection and proper insulated fittings must be used in accordance with the needs of the application.

The internal capacitors may run at 600 volts AC and are LETHAL when operating. The capacitors are safe when the unit is switched off, SO LONG AS THE 'CAPACITOR TO WINDING' CONNECTIONS ARE SOUND.

Only authorised and trained personnel should attempt repair.

8.3. Temperature

The steel stack of the unit may approach 70 °C above ambient, and precautions must be taken when repairing or testing exposed units.

All units should be well ventilated as power ratings assume natural air-cooling.

8.4. Chemicals

Once the manufacturing process is complete and all solvents have been burned off, the transformer is chemically benign.

The capacitors contain paper insulation soaked in transformer oil. This is relatively odourless and harmless to human skin. Although messy, this oil is only found if a capacitor leaks through some internal electrical fault in the capacitor.

If the capacitor is leaking, the transformer is faulty and should be switched off.

8.5. Mass

All our transformers have a very high density, and therefore suitable precautions should be taken with respect to the size and weight of the unit under consideration.

8.6. Noise

Audible noise at 50 Hz is emitted at different intensities depending on unit size. Sound levels range from 45 - 65 dBA.

If higher frequencies are present - checks should be made for potential faults.

Advance Electronics Limited. Advance Park, Wrexham. LL14 3YR United Kingdom

Sales: 01978 821 000 Fax: 01978 810 852 Accounts: 01978 821 149 Web: www.aelgroup.co.uk

Registered in England and Wales 1742090. An AEL Group Company

9. Service

Potential CVT problems are limited to:

- Incorrect rating of unit
- Incorrect or poor installation connections
- Winding open circuit
- Winding with short circuit turn
- Insulation failure
- Capacitor short circuit
- Capacitor open circuit

Except in special cases, service is limited to cleaning cooling fans, making poor connections good and replacing the AC capacitors.

9.1. Notes on Field Replacement of Capacitors

We are occasionally asked to supply replacement capacitors for old CVT's. Capacitors are subject to two characteristics, which affect the use of these spare components in CVT's.

9.1.1. Value tolerance

Changes in capacitance value will result in differences in the CVT output voltage. In general terms we expect normal production tolerances in the value of a spare capacitor to make less than a 1% change to the original output voltage nominal setting.

This situation can be improved when a coloured dot is noted on the failed capacitor, and its colour dot is defined at the time of ordering a spare. The output voltage variation expected with CVT's using a spare capacitor of the same colour dot will be less than 0.3%.

9.1.2. Physical dimensions

The physical dimensions of commercial capacitors change over extended periods of time. In general terms our replacement capacitors will be of similar size or smaller than the originals.

9.2. Spares/Repair

We are committed to providing long-term spares support for our units. Please ask your supplier for the location of your nearest AEL spares and repair centre.

Due to the special impregnation process it is unlikely that a normal re-wind house can repair our units.

It is essential to arrange for the return of damaged units, before shipping them to the factory.

For further information please contact our technical sales team:

Tel: (01978) 821000

Fax: (01978) 810852

AG 100 ~ 1000

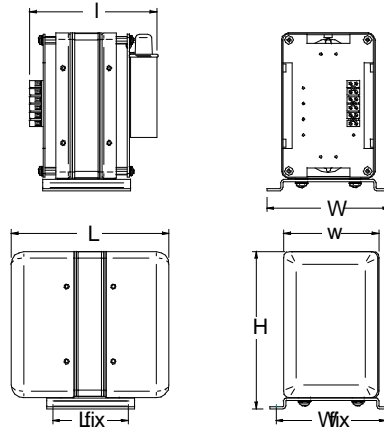
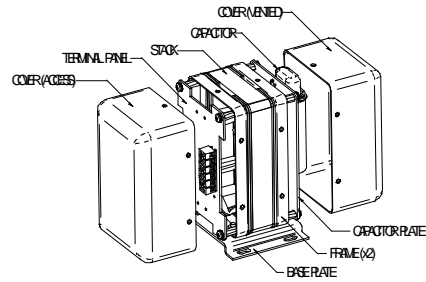

Relative scale 11

AG 1000 ~ 2500

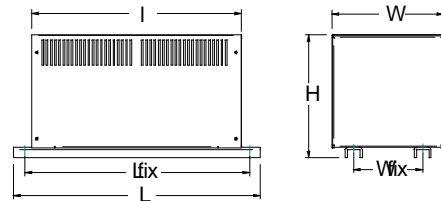
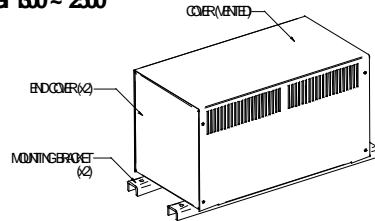

Relative scale 21

AG 3000 ~ 16000 (AT SIMILAR)

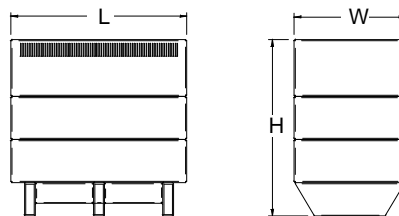
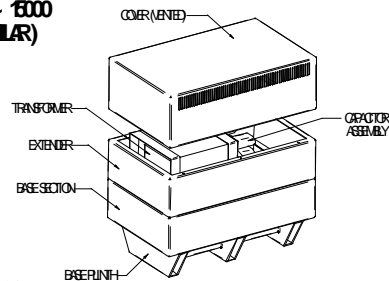

Relative scale 31

AG 100 ~ 1000 UNITS DIMENSIONS (mm&kg)

MODEL	Actual						Packed						fix centres	
	L	W	H	I	w	Wgt.	L	W	H	Wgt.	Lfix	Wfix		
AG 100	185	146	180	160	120	75	430	240	30	85	65	130		
AG 250	230	183	180	205	120	125	430	240	30	135	115	162		
AG 450	250	183	210	220	168	18	430	240	30	19	115	162		
AG 650	280	183	210	250	168	22	430	240	30	23	115	162		
AG 1000	320	183	210	305	168	32.5	660	500	43	36	180	162		

AG 1000 ~ 2500 UNITS DIMENSIONS (mm&kg)

MODEL	Actual						Packed						fix centres	
	L	W	H	I	w	Wgt.	L	W	H	Wgt.	Lfix	Wfix		
AG 1000	500	265	285	400	-	365	660	500	520	40	460	165		
AG 1600	500	265	285	400	-	42	660	500	520	46	460	165		
AG 2000	580	265	285	500	-	63	660	500	520	67	550	165		
AG 2500	580	265	285	500	-	72	660	500	520	76	550	165		

AG 3000 ~ 16000 UNITS DIMENSIONS (mm&kg)

MODEL	Actual						Packed						fix centres	
	L	W	H	I	w	Wgt.	L	W	H	Wgt.	Lfix	Wfix		
AG 3000	637	405	455	-	-	89	570	800	640	99	535	253		
AG 4000	637	405	455	-	-	100	570	800	640	110	535	253		
AG 5000	637	405	610	-	-	132.5	570	800	780	144.5	535	253		
AG 7000	637	405	610	-	-	168	570	800	780	-	535	253		
AG 8000	637	405	765	-	-	194	570	800	940	204	535	253		
AG 10000	637	405	765	-	-	212	570	800	940	212.5	535	253		
AG 12500	637	405	920	-	-	223	570	800	-	-	535	253		
AG 16000	637	405	920	-	-	243	570	800	-	255	535	253		

AT 3000 ~ 45000 UNITS DIMENSIONS (mm&kg)

MODEL	Actual						Packed						fix centres	
	L	W	H	I	w	Wgt.	L	W	H	Wgt.	Lfix	Wfix		
AT 3000	-	-	-	NA	NA	-	-	-	-	-	NA	NA		
AT 4800	-	-	-	NA	NA	-	-	-	-	-	NA	NA		
AT 6000	-	-	-	NA	NA	-	-	-	-	-	NA	NA		
AT 7500	-	-	-	NA	NA	-	-	-	-	-	NA	NA		
AT 9000	1325	660	773	NA	NA	-	-	-	-	-	NA	NA		
AT 12000	1325	660	773	NA	NA	-	-	-	-	-	NA	NA		
AT 16000	1325	660	773	NA	NA	-	-	-	-	-	NA	NA		
AT 21000	1325	660	773	NA	NA	-	-	-	-	-	NA	NA		
AT 24000	1325	660	773	NA	NA	-	-	-	-	-	NA	NA		
AT 37500	1325	660	773	NA	NA	-	-	-	-	-	NA	NA		
AT 45000	1325	660	773	NA	NA	-	-	-	-	-	NA	NA		

AG / AT
WEIGHTS & DIMENSIONS

DATE
11/10/04

REF:
L 144